

**Chasseleon Modulgehäuse**  
**Chasseleon Modular case**  
**Coffret modulaire Chasseleon**

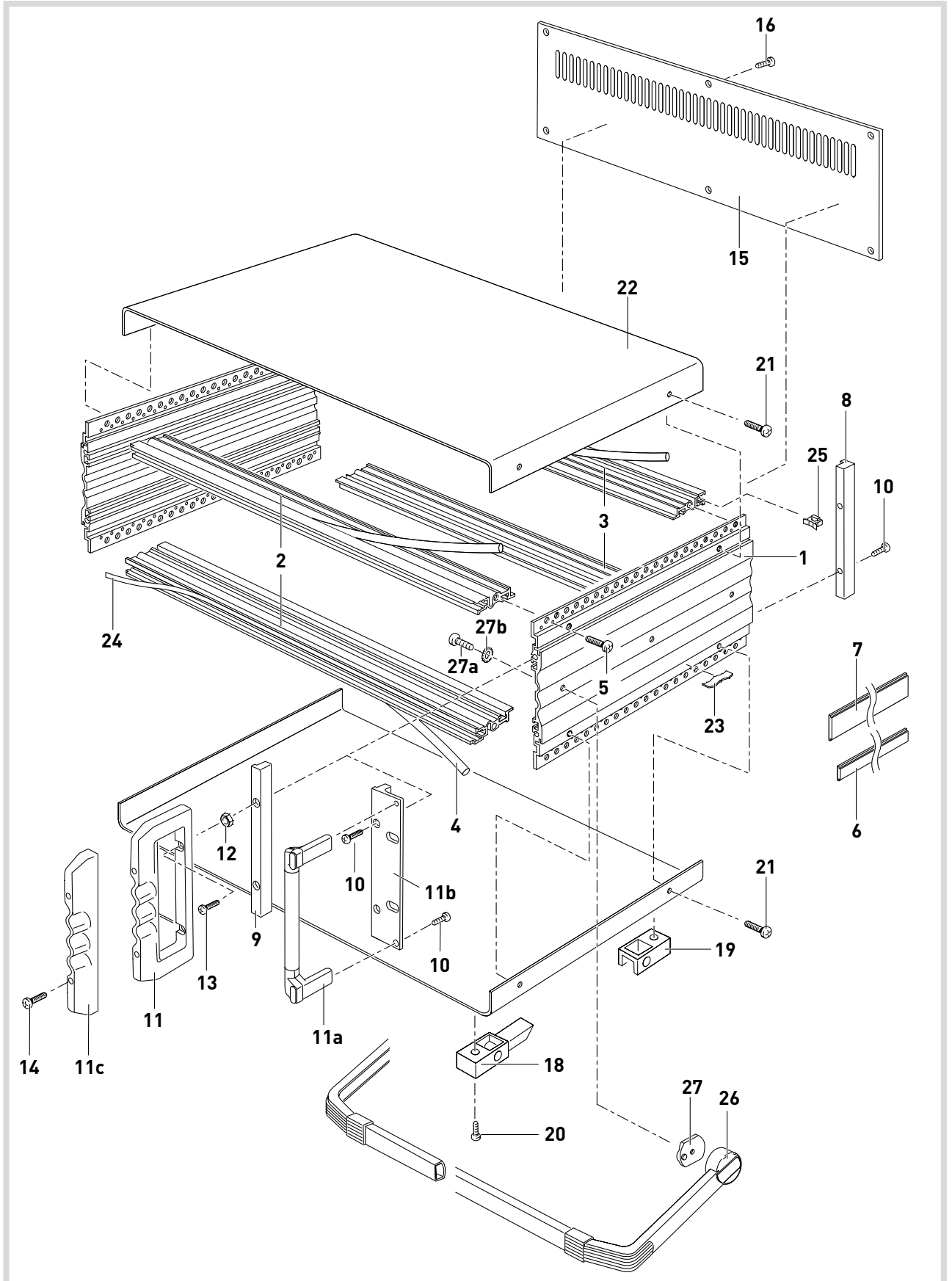

	Benennung Designation – Désignation	Anzahl Number – Nombre					Bemerkung Note – Observation
		2 HE	3 HE	4 HE	6 HE	7 HE	
1	Seitenprofil Side extrusion – Profil latéral	2	2	2	2	2	A Nur für Ausführung als Tischgehäuse Only for desktop unit Que pour modèle mobile
2	Querprofil, vorne Cross extrusion, front – Profil transversal avant	2	2	2	2	2	
3	Querprofil, hinten Cross extrusion, rear – Profil transversal arrière	2	2	2	2	2	
4	Dichtschnur Sealing strip – Corde de bourrage	4	4	4	4	4	B Nur für Ausführung als 19"-Einschub Only for 19" rack Que pour tiroir 19"
5	Linsenschraube M4 x 12 (≈ DIN 7985) Oval head screw – Vis à tête bombée	8	8	8	8	8	
6	Abdeckprofil, klein Cover section, small – Petit profil de recouvrement	–	–	2	–	2	C Nicht bei EMV-Ausführung Not for version EMC Pas pour modèle CEM
7	Abdeckprofil, groß Cover section, large – Grand profil de recouvrement	–	–	–	2	2	
8	Adapter, hinten Adaptor, rear – Adaptateur arrière	2	2	2	2	2	D Nur bei EMV-Ausführung Only for version EMC Que pour modèle CEM
9	Adapter, vorne Adaptor, front – Adaptateur avant	2	2	2	2	2	
10	Zylinderschraube m. l. M4 x 16 DIN 7984 Socket head cap screw – Vis cylindrée	8	8	8	8	8	E Für Ausführung mit Griff 11 For version with handle 11 Pour modèle avec poignée 11
11	Griff Handle – Poignée	2	2	2	2	2	
11a	Griff Handle – Poignée	2	2	2	2	2	F Nicht bei Ausführung als 19"- Einschub ohne Verkleidung Not for 19" rack without cover Pas pour le tiroir 19" sans revêtement
11b	19"-Adapter 19"-adaptor – Adaptateur 19"	2	2	2	2	2	
11c	Seitenabschluß Side strip – Fermeture latérale	–	2	2	–	–	G Nur für Ausführung mit Trage- und Aufstellgriff 26 Only for versios with carrying and installation handle 26 Seulement pour modèle avec poignée support et redressable 26
12	Erdungshülse Grounding sleeve – Cosse de mise à la terre	4	4	4	4	4	
13	Zylinderschraube m. l. M4 x 25 DIN 7984 Socket head cap screw – Vis cylindrée	4	4	4	4	4	A, C
14	Zylinderschraube m. l. M4 x 40 DIN 7984 Socket head cap screw – Vis cylindrée	4	4	4	4	4	
15	Rückwand Rear panel – Paroi arrière	1	1	1	1	1	E
16	Linsenschraube M2,5 x 10 DIN 7985 Oval head screw – Vis à tête bombée	6	6	6	6	6	
17	Boden Bottom – Fond	1	1	1	1	1	F
18	Aufstellfuß Mounting foot – Pied redressable	2	2	2	2	2	
19	Anschraubfuß Screw-on foot – Pied vissable	2	2	2	2	2	A
20	Linsenschraube M3 x 8 DIN 7985 Oval head screw – Vis à tête bombée	4	4	4	4	4	
21	Linsenschraube M4 x 5 DIN 7985 Oval head screw – Vis à tête bombée	8	8	8	8	8	C
22	Deckel Lid – Couvercle	1	1	1	1	1	
23	Erdungsstreifen Grounding strip – Bandes de mise à la terre	2	2	2	2	2	F, C
23a	EMV-Dichtung EMC seal – Cordon d'étanchéité CEM	4	4	4	4	4	
24	Beschriftungsstreifen Labelling strip – Bandes d'inscription	4	4	4	4	4	D
25	Schiebemutter M2,5 Slide nut – Écrou coulisse	6	6	6	6	6	
25a	Gewindeleiste Tapped strip – Tringle fileté	2	2	2	2	2	D
26	Trage- und Aufstellgriff – Carrying and installation handle – Poignée support et redressable	–	1	1	–	–	
27	Adapter Adaptor – Adaptateur	–	2	2	–	–	G
27a	Linsenschraube M4 x 12 DIN 7985 Oval head screw – Vis à tête bombée	–	2	2	–	–	
27b	Zahnscheibe Tooth lock washer – Pignon	–	2	2	–	–	G



## 2.1

**Quer- und Seitenprofile**

Schiebemuttern oder EMV-Gewindeleisten

- Schiebemuttern **25** oder Gewindeleisten **25a** bei EMV hinten in die Querprofile **3** einschieben.

**Cross and side extrusions**

Sliding nuts or EMC tapped strips

- Push sliding nuts **25** or tapped strips **25a** only EMC into the rear of the cross extrusions **3**.

**Profils transversaux et latéraux**

Écrous-coulisse ou tringles filetée CEM

- Pousser les écrous-coulisse **25** ou les tringles filetée **25a** que pour CEM dans les profils arrière **3**.

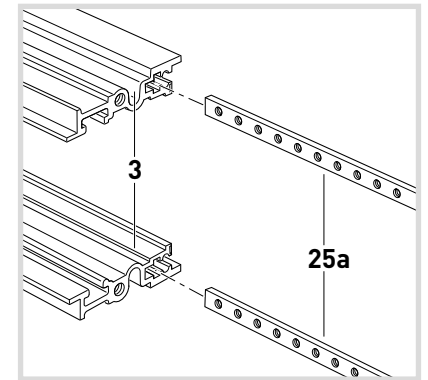
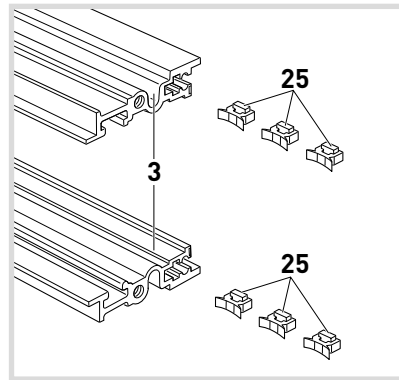

## Hinweis

**Vor dem Montieren der Querprofile auf eventuelle Befestigung von Zubehörteilen achten (siehe 2.4, 2.5 und 3).**

**Bei den Querprofilen vorne/hinten auf das Maß achten!**

## Information

**Before assembling the vertical extrusions pay attention to the fitting of accessories if required (see 2.4, 2.5 and 3).**

**Note dimension for cross extrusion front/rear!**

## Nota

**Avant le montage des profils transversaux veuillez vérifier la fixation des accessoires si nécessaire (voir 2.4, 2.5 et 3).**

**Pour les profils arrière/avant faire attention aux dimensions!**

## Dichtschnüre

- Dichtschnüre **4** in die Querprofile **2** und **3** eindrücken.

## Sealing strips

- Press sealing strips **4** into the cross extrusions **2** and **3**.

## Cordes de bourrage

- Enforcer les cordes de bourrage **4** dans les profils transversaux **2** et **3**.

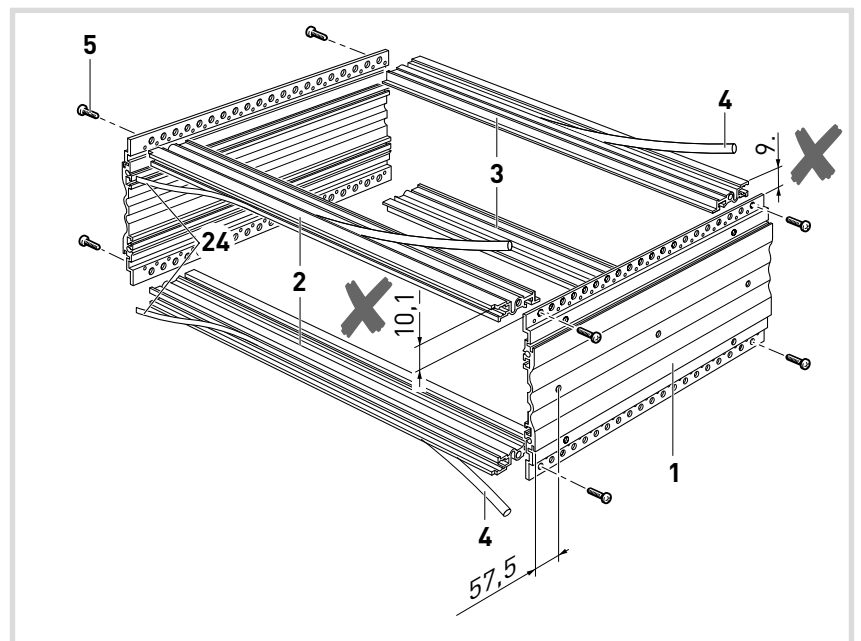

Bei Ausführung 19"-Einschub, vorne

19"-chassis version, front

Seulement au tiroir 19", à l'avant

## Abdeckprofile

- Abdeckprofile **6** oder **7** in die Seitenprofile **1** einschieben.

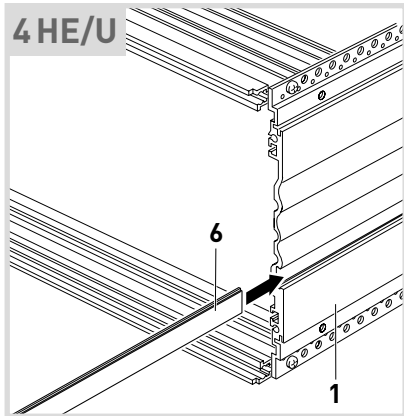

## Cover sections

- Push cover sections **6** or **7** into the side extrusions **1**.

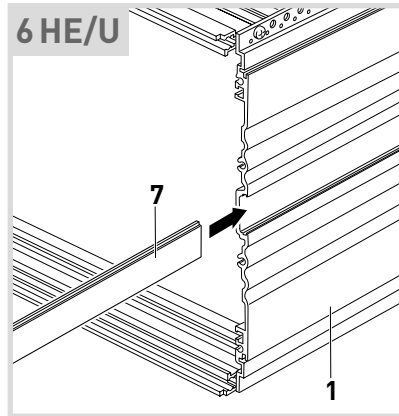

## Profils de recouvrement

- Pousser les profils de recouvrement **6** ou **7** dans les profils latéraux **1**.

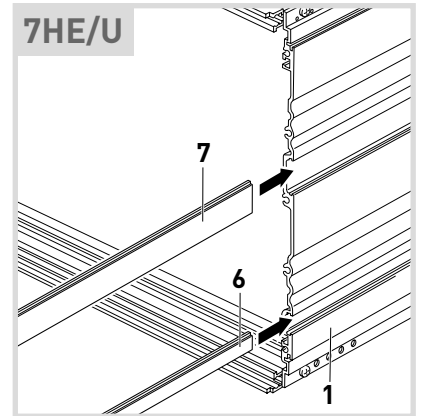

## 2.2

## Adapter

## Hinweis

**Vor der Montage der Adapter vorne und hinten Gewindeleisten oder Schiebemuttern (Zubehör, nicht im Lieferumfang enthalten) in die Querprofile vorne/hinten einschieben.**

Hintere Adapter **8** sind verkürzt.



## Adaptor

## Information

**Push in threaded strip or slide nuts (accessory not included in the scope of delivery) into the cross extrusions front/rear prior to the assembly of front and rear adaptors.**

Rear adaptors **8** are shortened.

## Adaptateur

## Nota

**Avant de monter l'adaptateur mettre, broche taraudée à l'avant, ou écrous-coulisse à l'arrière, dans les profils latéraux.**

Les adaptateurs arrières **8** sont raccourcis.

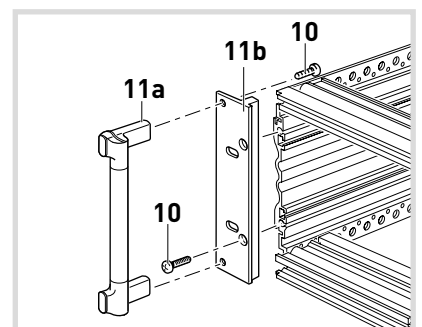
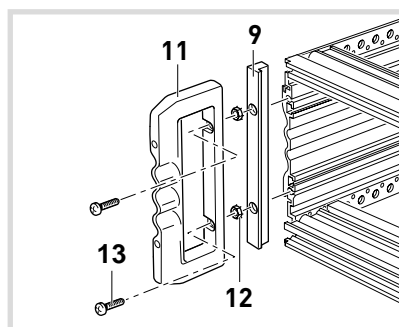
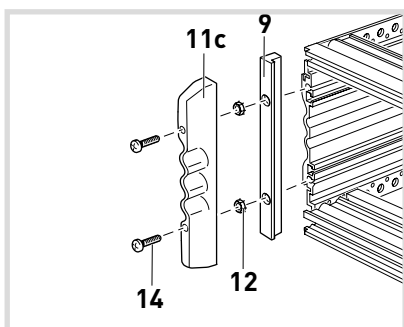
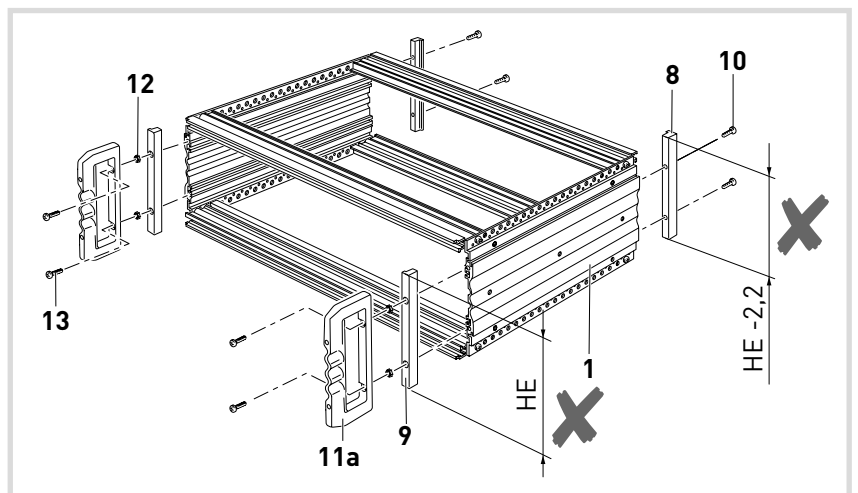

## 2.3

## Rückwand

- Rückwand **15** mit den Linsenschrauben **16** (M2,5) an den Schiebemuttern **25** oder den Gewindeleisten **25a** (nur EMV) in den Querprofilen, hinten **3** befestigen.

## Rear panel

- Attach rear panel **15** with the oval head screws **16** (M2,5) to the slide nuts **25** or the tapped strip **25a** (only EMC) in the rear of the cross extrusions **3**.

## Paroi arrière

- Fixer la paroi arrière **15** avec les vis à tête bombée **16** (M2,5) sur les écrous-coulisse **25** ou la tringle filetée **25a** (que pour CEM) sur les profils latéraux à l'arrière **3**.

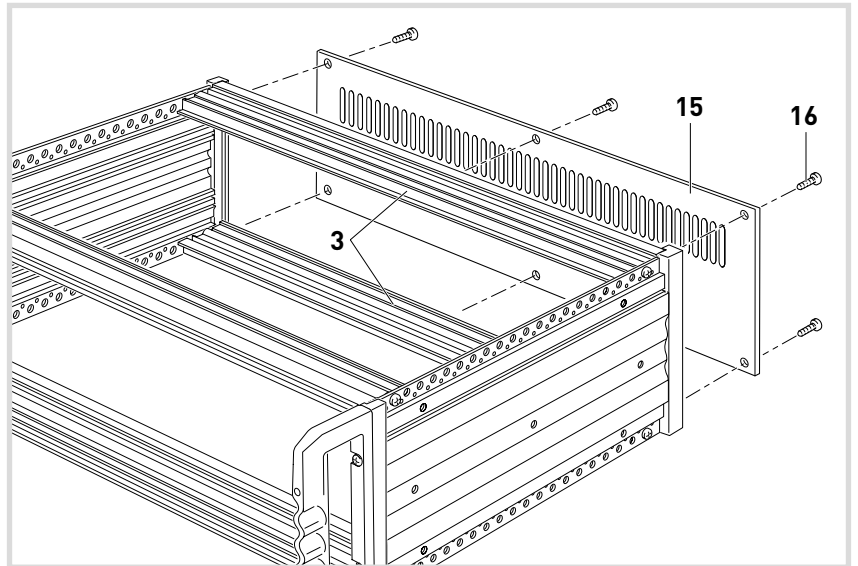

EMC – EMC – CEM

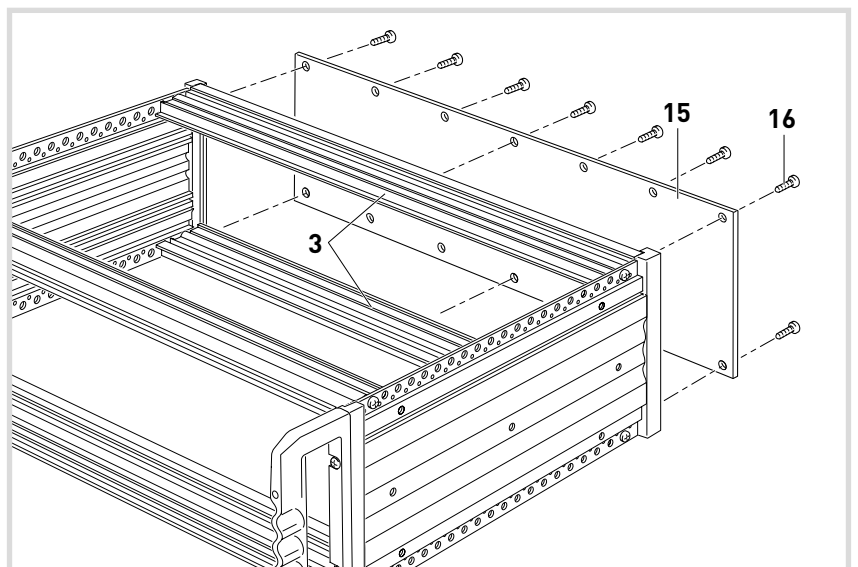

2.4

**Boden und Deckel**

- Aufstellfüße 18 und Anschraubfüße 19 an der Unterseite des Bodens 17 befestigen.

Hinweis

**Vor Deck- und Bodenblechmontage zusätzliche Querprofile (Zubehör, nicht im Lieferumfang enthalten) einbauen.**



**Bottom and lid**

- Attach mounting feet 18 and screw-on feet 19 on the underside of bottom panel 17.

Information

**Insert additional cross extrusions (accessory not included in the scope of delivery) prior to the assembly of top and bottom plates.**

**Fond et couvercle**

- Fixer les pieds redressables 18 et pieds vissables 19 sur le dessous du boîtier 17.

Nota

**Installer les profils latéraux avant de procéder au montage des coiffes (accessoire: ne font pas partie de la livraison).**

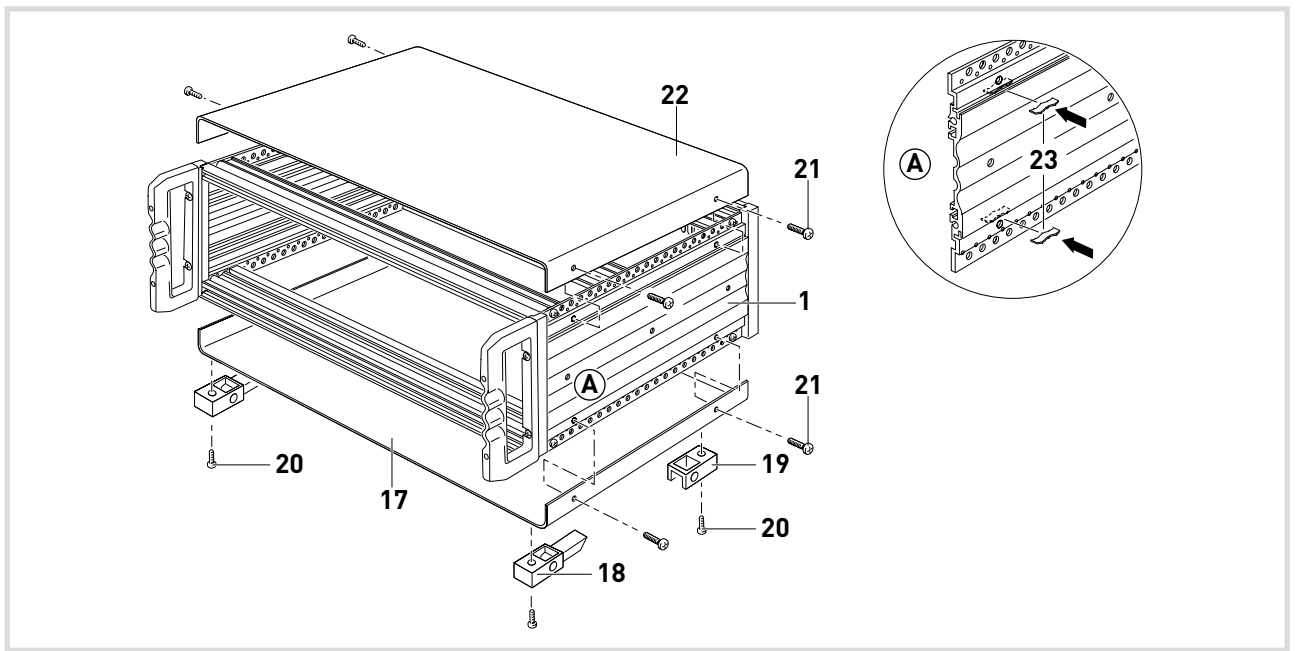

EMC – EMC – CEM

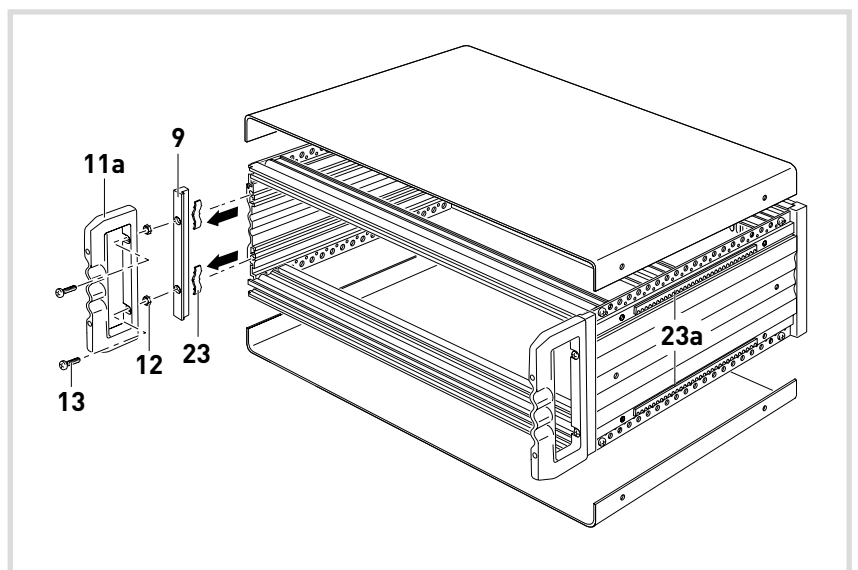

## 3.1

## Teleskopschienen

## Telescope slides

## Glissières télescopique

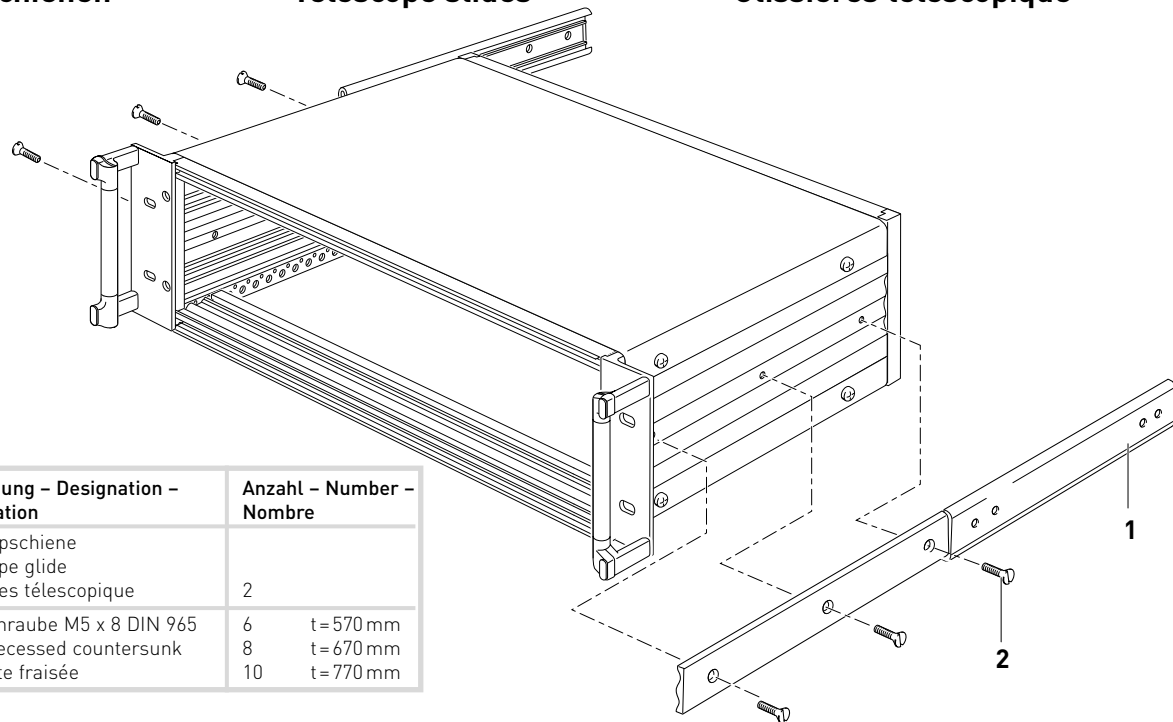

	Benennung - Designation - Désignation	Anzahl - Number - Nombre
1	Teleskopschiene Telescope glide Glissières télescopique	2
2	Senkschraube M5 x 8 DIN 965	6 t=570 mm
	Cross recessed countersunk	8 t=670 mm
	Vis à tête fraisée	10 t=770 mm

## 3.2

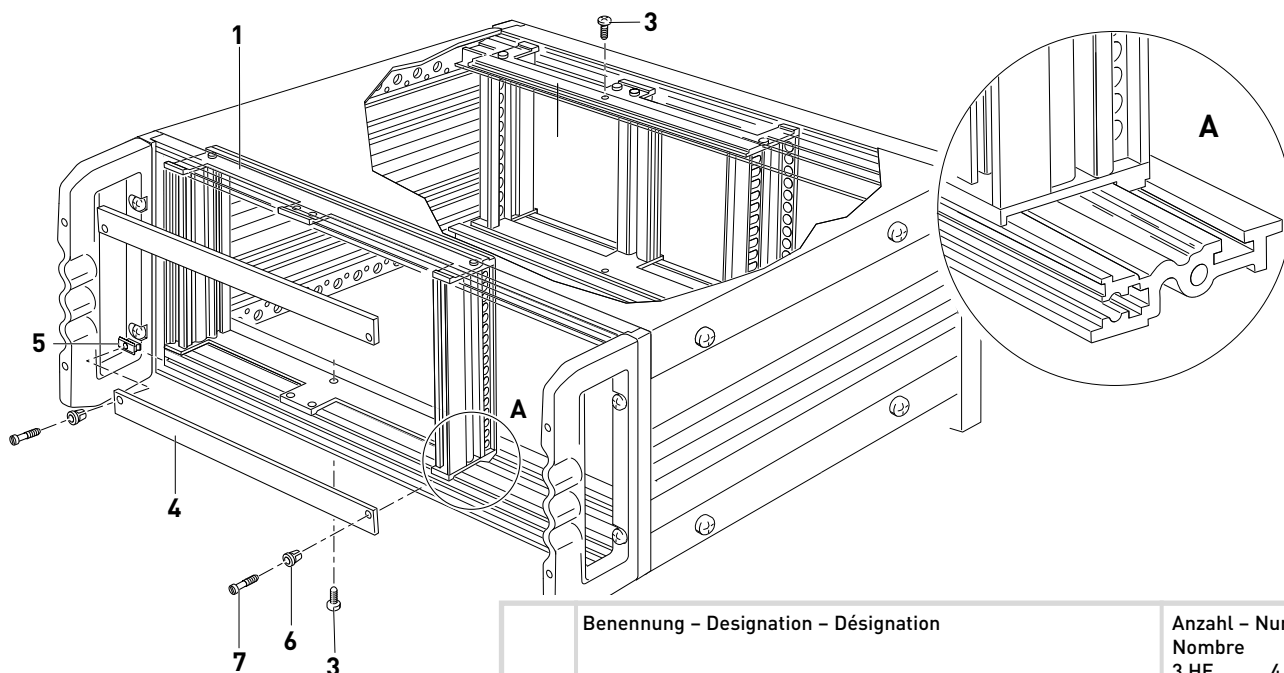
Einbausatz horizontal  
3 und 4 HEHorizontal installation kit  
3 and 4 ULot de montage horizontal  
3 et 4 HE

	Benennung - Designation - Désignation	Anzahl - Number - Nombre	
		3 HE	4 HE
1	Rahmen, vorn - Frame, front - Cadre avant	1	1
2	Rahmen, hinten - Frame, rear - Cadre arrière	1	1
3	Linsenschraube M2,5 x 8 - Oval head screw - Vis à tête bombée	4	4
4	Blende - Screen - Toise	2	2
5	Schiebemutter M2,5 - Slide nut - Écrou coulisse	4	4
6	Schraubensicherung - Screw retention - Frein de vis	4	4
7	Sonderschraube M2,5 - Special screw - Vis spéciale	4	4

4.1

3 HE

A: Für Steckerleisten nach DIN 41612/41617 sowie BUS-Platinen.

B: Mit integriertem Steckerträger DIN 41612.

- 1 Profil – extrusion – profil  
42 TE/HP: B.N. 2.310.547.9  
63 TE/HP: B.N. 2.310.544.9  
84 TE/HP: B.N. 2.310.545.9

- 2 Profil – extrusion – profil  
42 TE/HP: B.N. 2.310.552.9  
63 TE/HP: B.N. 2.310.556.9  
84 TE/HP: B.N. 2.310.550.9

3 U

A: For multipoint connectors conforming DIN 41612/41617 and BUS PCBs.

B: With integrated plug carrier DIN 41612.

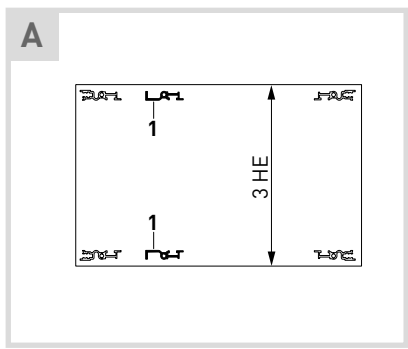

3 HE

A : Pour connecteur multibroche d'après DIN 41612/41617 ainsi que platines-bus.

B : Avec support de broche intégré DIN 41612.

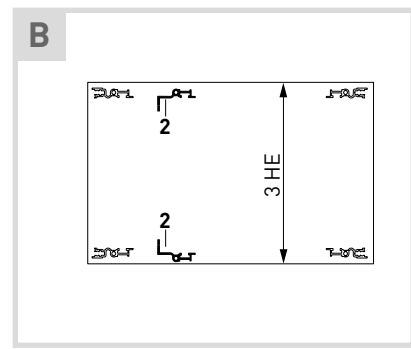

4.2

4 HE

Unterteilt in 3 und 1 HE

A: Für Steckerleisten nach DIN 41612/41617 sowie BUS-Platinen.

B: Mit integriertem Steckerträger DIN 41612.

- 1 Profil – extrusion – profil  
42 TE/HP: B.N. 2.310.547.9  
63 TE/HP: B.N. 2.310.544.9  
84 TE/HP: B.N. 2.310.545.9

- 2 Profil – extrusion – profil  
42 TE/HP: B.N. 2.310.552.9  
63 TE/HP: B.N. 2.310.556.9  
84 TE/HP: B.N. 2.310.550.9

- 3 Profil – extrusion – profil  
42 TE/HP: B.N. 2.310.537.9  
63 TE/HP: B.N. 2.310.539.9  
84 TE/HP: B.N. 2.310.541.9

4 U

Subdivided into 3 and 1 U

A: For multipoint connectors conforming DIN 41612/41617 and BUS PCBs.

B: With integrated plug carrier DIN 41612.

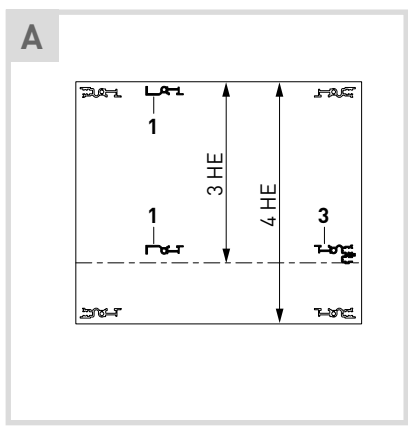

4 HE

Divisé en 3 et 1 HE

A : Pour connecteur multibroche d'après DIN 41612/41617 ainsi que platines-bus.

B : Avec support de broche intégré DIN 41612.

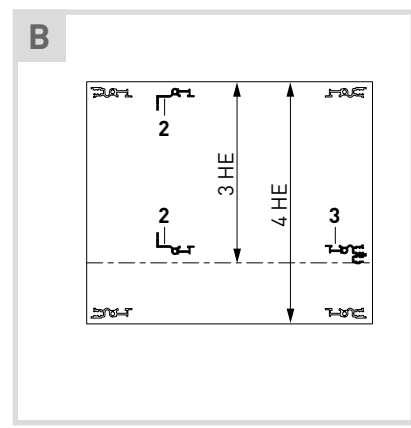

## 4.3

## 6 HE

A, C: Für Steckerleisten nach DIN 41612/41617 sowie BUS-Platinen.

B, D: Mit integriertem Steckerträger  
DIN 41612.

**1 Profil – extrusion – profil**

42 TE/HP: B.N. 2.310.547.9  
63 TE/HP: B.N. 2.310.544.9  
84 TE/HP: B.N. 2.310.545.9

**2 Profil – extrusion – profil**

42 TE/HP: B.N. 2.310.552.9  
63 TE/HP: B.N. 2.310.556.9  
84 TE/HP: B.N. 2.310.550.9

**4 Profil – extrusion – profil**

42 TE/HP: B.N. 2.350.432.9  
63 TE/HP: B.N. 2.350.435.9  
84 TE/HP: B.N. 2.350.434.9

**5 Profil – extrusion – profil**

42 TE/HP: B.N. 2.350.452.9  
63 TE/HP: B.N. 2.350.455.9  
84 TE/HP: B.N. 2.350.454.9

Unterteilt in 2 x 3 HE

**1 Profil – extrusion – profil**

42 TE/HP: B.N. 2.310.547.9  
63 TE/HP: B.N. 2.310.544.9  
84 TE/HP: B.N. 2.310.545.9

**2 Profil – extrusion – profil**

42 TE/HP: B.N. 2.310.552.9  
63 TE/HP: B.N. 2.310.556.9  
84 TE/HP: B.N. 2.310.550.9

**6 Profil – extrusion – profil**

42 TE/HP: B.N. 2.310.512.9  
63 TE/HP: B.N. 2.310.509.9  
84 TE/HP: B.N. 2.310.508.9

## 6 U

A, C: For multipoint connectors conforming DIN 41612/41617 and BUS PCBs.

B, D: With integrated plug carrier  
DIN 41612.

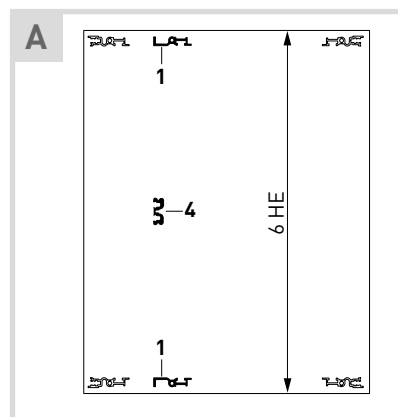

## 6 HE

A, C : Pour connecteur multibroche d'après DIN 41612/41617 ainsi que platines-bus.

B, D : Avec support de broche intégré  
DIN 41612.

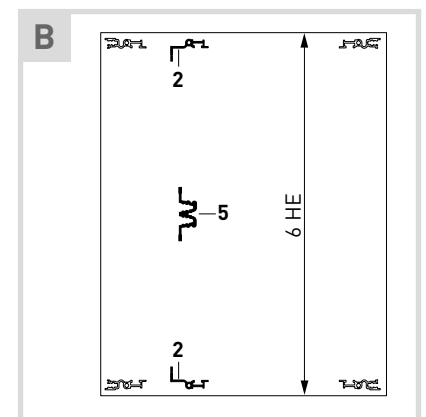

Subdivided into 2 x 3 U

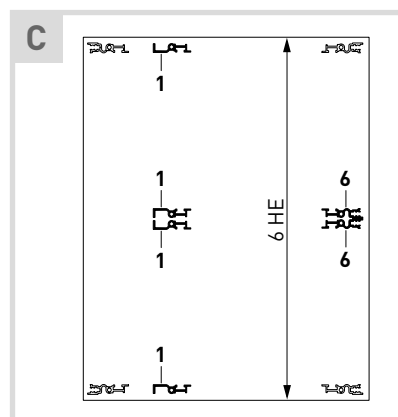

Divisé en 2 x 3 HE

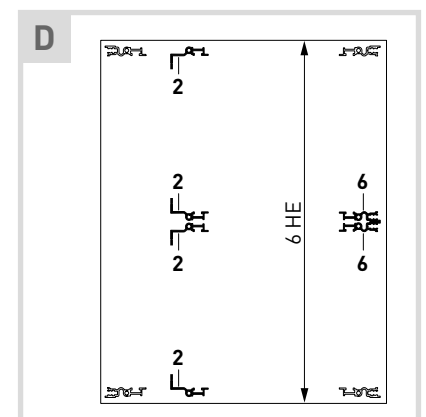

4.4

7 HE

A, C: Für Steckerleisten nach DIN 41612/41617 sowie BUS-Platinen.

B, D: Mit integriertem Steckerträger  
DIN 41612.

Unterteilt in 6 und 1 HE

1 Profil – extrusion – profil

42 TE/HP: B.N. 2.310.547.9  
63 TE/HP: B.N. 2.310.544.9  
84 TE/HP: B.N. 2.310.545.9

2 Profil – extrusion – profil

42 TE/HP: B.N. 2.310.552.9  
63 TE/HP: B.N. 2.310.556.9  
84 TE/HP: B.N. 2.310.550.9

3 Profil – extrusion – profil

42 TE/HP: B.N. 2.310.537.9  
63 TE/HP: B.N. 2.310.539.9  
84 TE/HP: B.N. 2.310.541.9

4 Profil – extrusion – profil

42 TE/HP: B.N. 2.350.432.9  
63 TE/HP: B.N. 2.350.435.9  
84 TE/HP: B.N. 2.350.434.9

5 Profil – extrusion – profil

42 TE/HP: B.N. 2.350.452.9  
63 TE/HP: B.N. 2.350.455.9  
84 TE/HP: B.N. 2.350.454.9

Unterteilt in 2 x 3 HE und 1 HE

1 Profil – extrusion – profil

42 TE/HP: B.N. 2.310.547.9  
63 TE/HP: B.N. 2.310.544.9  
84 TE/HP: B.N. 2.310.545.9

2 Profil – extrusion – profil

42 TE/HP: B.N. 2.310.552.9  
63 TE/HP: B.N. 2.310.556.9  
84 TE/HP: B.N. 2.310.550.9

3 Profil – extrusion – profil

42 TE/HP: B.N. 2.310.537.9  
63 TE/HP: B.N. 2.310.539.9  
84 TE/HP: B.N. 2.310.541.9

6 Profil – extrusion – profil

42 TE/HP: B.N. 2.310.512.9  
63 TE/HP: B.N. 2.310.509.9  
84 TE/HP: B.N. 2.310.508.9

7 U

A, C: For multipoint connectors conforming DIN 41612/41617 and BUS PCBs.

B, D: With integrated plug carrier  
DIN 41612.

Subdivided into 6 and 1 U

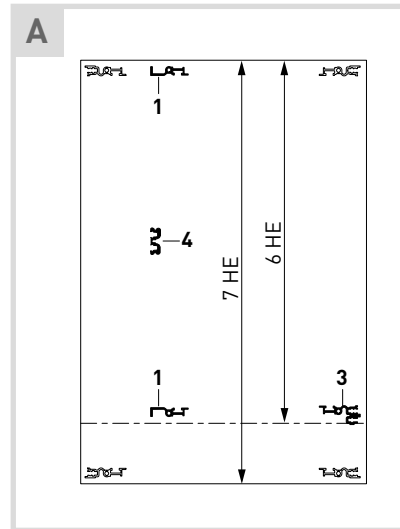

7 HE

A, C : Pour connecteur multibroche d'après DIN 41612/41617 ainsi que platines-bus.

B, D : Avec support de broche intégré  
DIN 41612.

Divisé en 6 et 1 HE

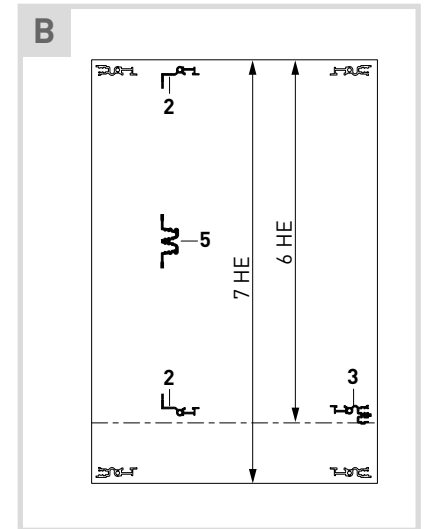

Subdivided into 2 x 3 U and 1 U

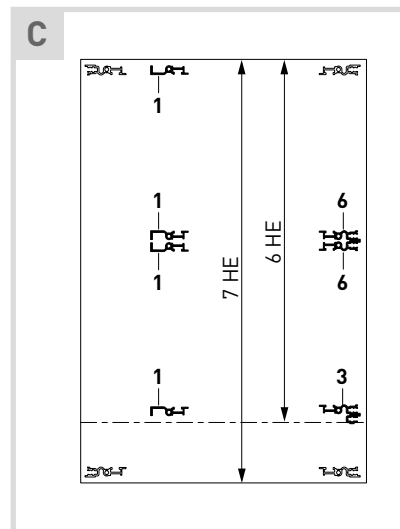

Divisé en 2 x 3 HE et 1 HE

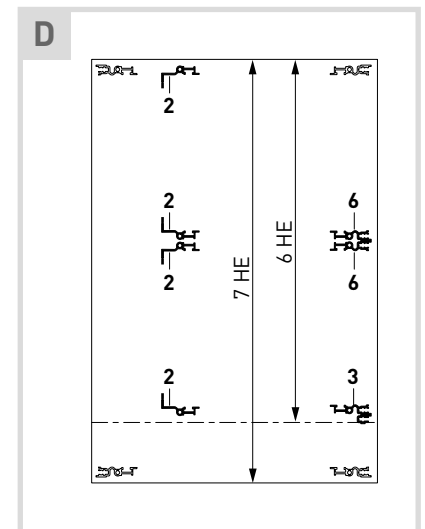



**knürr**  
environments for electronics

**Knürr AG**

Mariakirchener Straße 38  
94424 Arnstorf • Germany  
Telefon +49 (0) 87 23 / 27 - 0  
Telefax +49 (0) 87 23 / 27 - 154  
[www.knuerr.com](http://www.knuerr.com)