

FULLY INTEGRATED WORKPLACE SOLUTIONS

COMPLETE CONTROL. MAXIMUM FLEXIBILITY.

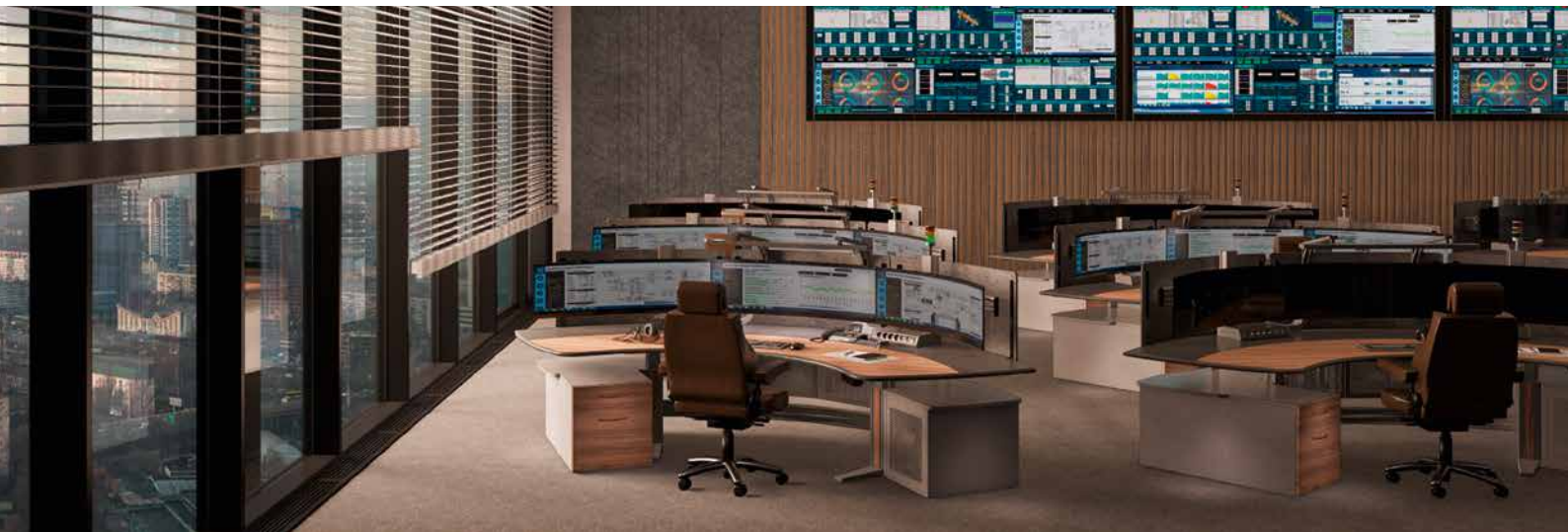

Flexible solutions for every workplace requirement

Modern workplaces place ever-increasing demands on efficiency, ergonomics and IT security, whether in an office, a control room or a data centre.

The new fully integrated workstation solutions from Knürr and IHSE offer tailor-made concepts for ergonomic, secure and scalable control rooms. The combination of high-quality Ergocon consoles from Knürr and in-

tegrated KVM technology from IHSE ensures maximum efficiency, ease of use and the highest reliability.

Our pre-defined models are ready-to-buy, tried and tested, and cover a range of requirements – from ergonomic single workstations to high-end matrix solutions for large control rooms.

SCOPE OF DELIVERY

 <p>Knürr console Ergocon®</p>	 <p>IHSE KVM system Draco®</p>	 <p>Technical specification Power supply, mounts, accessories</p>
 <p>Peripherals & Accessories Keyboard, mouse, cable</p>	 <p>Installation & Commissioning Professional service</p>	 <p>Warranty & Maintenance Guaranteed operational reliability</p>

OPTIONS

Monitors, LCD/LED video walls, room layout, acoustics, lighting, chairs

CORE

COMPUTERS AT THE WORKPLACE

MAXIMUM EFFICIENCY WITH JUST A KEYBOARD AND MOUSE



In the day-to-day operations of modern control and command centres, operators are often faced with the challenge of having to monitor and control multiple systems simultaneously. Different keyboards, mice and computers mean constant reaching, confusion and ergonomic strain. With the fully integrated 'CORE' workstation, these problems are a thing of the past: **all**

computers to be operated are built directly into the workstation and can be conveniently controlled using just one keyboard and mouse. Each computer has its own monitors. This means all systems remain in view at the same time. This reduces the number of peripherals, saves space and significantly increases efficiency and user comfort.

ADVANTAGES

- **Fully integrated workstation:** Technology, ergonomics and design combined – all systems and controls are integrated into the console. This ensures a tidy and efficient working environment.
- **Central control:** All connected computers can be operated using just one set of input devices.
- **Greater ergonomics and comfort:** Less hardware means more space and a clearer overview.
- **Direct performance:** Computers remain on-site at the workplace – for maximum security and speed.

Result: An ergonomic, integrated and intuitive workstation that reduces operator strain and boosts productivity.



Workstation/
Console

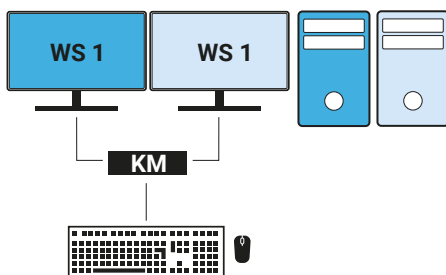

REMOTE

COMPUTER LOCATED IN THE SERVER ROOM

THE REMOTE WORKSTATION SOLUTION FOR MAXIMUM ERGONOMICS AND SAFETY



In many work environments, loud fan noise, heat build-up and tangled cables disrupt the flow of concentrated work. This causes operators to tire more quickly, and the workstation feels chaotic and unergonomic. The fully integrated **“REMOTE”** workstation elegantly solves these problems:

The computers are securely housed in the server room, whilst only the KVM technology remains at the workstation.

Everything is conveniently controlled via a keyboard and mouse – simple, efficient and without compromising on performance.



ADVANTAGES

- **Fully integrated workstation:** Technology, ergonomics and design combined – all systems and controls are integrated into the console. This ensures a tidy and efficient working environment.
- **Relocation of the computers:** Space-saving and housed centrally in the server room.
- **Less noise & heat:** No noisy fans or heat sources in the office.
- **Optimal ergonomics:** Operated using just a keyboard and mouse.
- **Access control:** Greater security through physical separation.
- **Longer service life:** Protection of the hardware through a controlled server room environment.
- **Flexibility:** Ideal for modern multi-monitor workstations.

Result: A quiet, tidy and ergonomically optimised workspace that promotes greater concentration, comfort and safety.

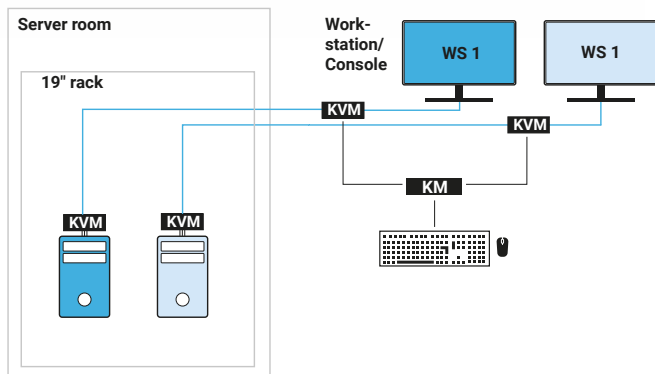

FLEX

CENTRALLY LOCATED SERVERS WITH MATRIX SWITCHING

MAXIMUM FLEXIBILITY WITH CENTRALISED ACCESS TO ALL COMPUTERS



In modern control rooms, operators often need to access numerous systems located in different places. This frequently results in complicated access routes, a limited overview and a lack of flexibility in operation. The fully integrated 'FLEX' workstation solution with centrally located computers provides a remedy: **all systems are operated securely in the server room, whilst users can flexibly access any computer from various**

Ergocon workstations. Thanks to the integrated KVM technology, systems can be switched seamlessly and operated using just one keyboard and mouse. Individually configurable access rights, centralised management and functions such as remote administration, user management and controlled switching make the solution ideal for high-end control rooms where maximum efficiency, security and ease of use are required.



ADVANTAGES

- **Relocation of the computers:** Space-saving and housed centrally in the server room.
- **Consistent operation and complete flexibility:** Every workstation can access the remote PCs via a keyboard and mouse – including redundancy through multiple connections.
- **Remote administration:** Efficient remote management of systems.
- **User management:** Control of access rights for maximum security.
- **Scalability:** Organisation of a wide range of resources and workstations.

Result: A highly flexible, centrally managed network of workstations with a clear structure, simple operation and optimal ergonomics is crucial.

